

IRIS 800

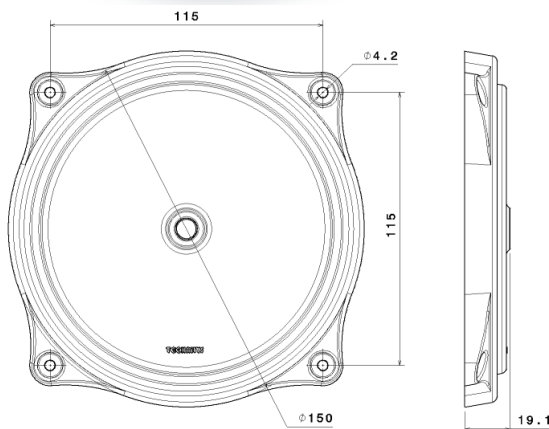

CEILING LIGHT WITH SENSOR

- # Infrared movement sensor
- # Glass in Polycarbonat (PC)
- # Beam angle : 120°
- # Connection by wires (lg 10cm)
- # Non-depolarized product
- # Various timing available (10mn, 20mn or 30mn)
- # Very high level of efficiency, luminous flux vs consumption

LED COLOR TEMPERATURE

- # Cool white (6000-6500K)
- # Neutral white (4000-4500K)

TECHNILYS +

Thin and low-profile product

Non visible leds when product is switch off

Infrared sensor : detect the temperature's variations. No detection of moving objects.

TECHNICAL DATA

LED : TYPE & NUMBER	8 OSRAM S5 LEDS
BEAM ANGLE	120°
LUMINOUS FLUX	800 LUMEN
CONSUMPTION	7,5W
SUPPLY	12/24V
DIMENSIONS (L X H) – MM -	180 X 19
WATERPROOF LEVEL	N.A

PART NUMBERS

LED COLOR T°	PART NUMBER	WATERPROOF
NEUTRAL WHITE	240474N	IP69
COOL WHITE	240474C	IP69